



XE80U

EXCAVATOR



www.xcmg.net.au

PERFORMANCE, RELIABILITY & VALUE

GLOBAL DOMINANCE

XCMG is the World's 3rd largest construction machinery manufacturer, with branches, dealers and service agents throughout Australia.

EASY SERVICE ACCESS

All daily maintenance points are easily reached and serviced from the ground, ensuring simple day-to-day checks for the operator.

SAFETY VALVES

Together with the blade-holding valve, the XE80U includes boom and arm safety valves as standard. This ensures the operator can handle digging and lifting tasks with maximum safety.

EXCEPTIONAL HYDRAULICS

The XCMG 219 LPM hydraulic flow system delivers precise oil control to attachments using two load sensing standard hydraulic circuits.

KUBOTA ENGINE

Renowned Kubota V3307, diesel engine - equipped with EGR, DOC, DPF and automatic dust evacuation whilst ensuring fuel efficiency and smooth control.

INTELLIGENT DESIGN

The innovative and practical design includes a spacious ROPS and OPG climate-controlled cab and ergonomic setup with air suspension seat, delivering unmatched comfort and control.

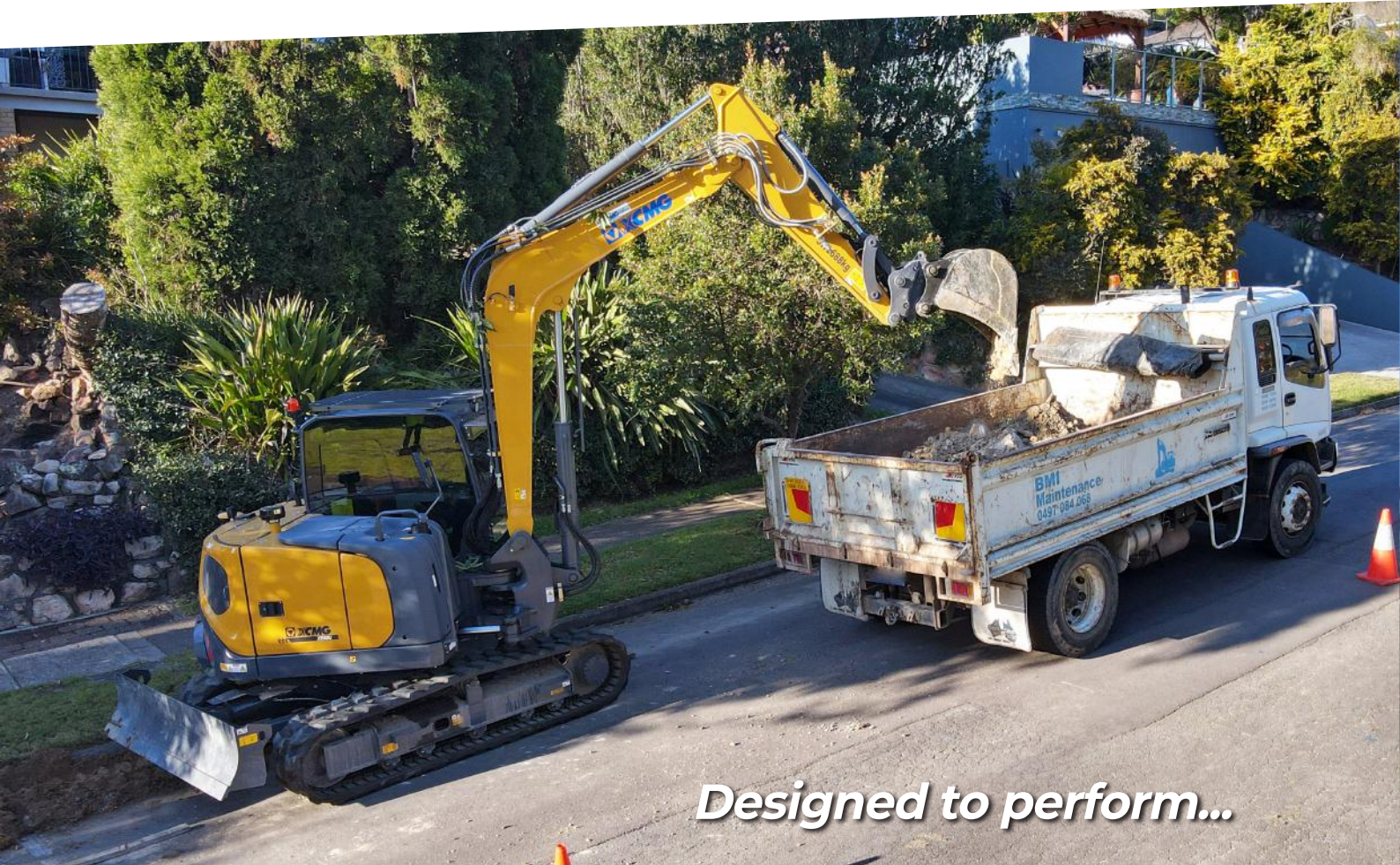

Designed to perform...

EXCAVATOR

RELIABILITY & TRUST

XCMG's key focus is the complete satisfaction and success of every machine owner - making your business as profitable as possible.

UNMATCHED SUPPORT

Your local dealer provides exceptional support throughout your machine's life: operation, maintenance and service from delivery to its very last day on the job.

COMPACT DESIGN

The short boom and tail swing designs allow the operator to work in narrow areas - which makes the XE80U capable of completing complex jobs in difficult conditions.

EFFICIENT RETURN

Main pump provides fast response, low speed, high torque, and low energy consumption creates reduced pressure loss and improved operating conditions.

ENGINE MAINTENANCE

The XE80U has a one side maintenance design and is lower in cost with longer service intervals - resulting in reduced operating expenses, less downtime and optimal machine availability on-site.

OPERATOR COMFORT

Air conditioning with cooling and heating temperature control, a multi-channel stereo sound system, ample storage, and colour LCD display ensures operator comfort all day long.



...built to last.

XE80U



Easy service access to all componentry



Air suspension seat and user friendly joystick controls



8 inch screen display with detailed page layout



Reverse camera and back work lights

EXCAVATOR



XE80U LIFTING CAPACITY

Lift Point Height	Over Front						Over Side						Max Radius (mm)			
	Lift at Max Radius (kg)	1 m	2 m	3 m	4 m	5 m	6 m	Lift at Max Radius (kg)	1 m	2 m	3 m	4 m		5 m	6 m	
6	1768			3436	2410			1424				3167	1985			4000
5	1333			2712	2471	1722		1075				2712	1991	1395		5000
4	1136				2406	1697	1268	914				1928	1371	1024		6000
3	1034					1639	1247	829					1316	1004		6000
2	987					1570	1214	789					1251	973		6000
1	980					1513	1183	783					1196	943		6000
0	1016					1480	1164	811					1165	925		6000
-1	1077				2009	1474	1166	883				1556	1160	927		6000
-2	688				1639	1293		688				1586	1182			5000

XE80U SPECIFICATIONS

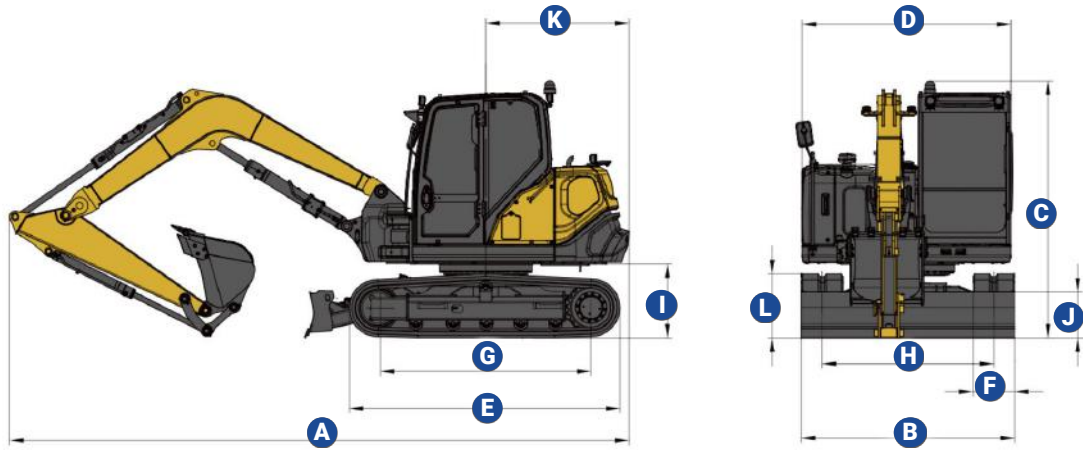

XE80U	A	B	C	D	E	F	G	H	I	J	K	L
mm	6585	2300	2730	2250	2900	450	2272	1850	818.5	386.5	1450/1545	698

KEY PERFORMANCE SPECIFICATIONS

Key Specs	Operating Weight:	9500 kg
	Engine Model:	Kubota/V3307CRTE5
	Maximum Torque:	265/1500 N.m
	Maximum Power:	54.6 kW @ 2200 rpm
	Fuel Tank Capacity:	130 L
	Piston Displacement:	3.3 L
	Maximum Travel Speed:	2.7 - 4.9 kmph
	Grade Ability:	35 °/70%
	Ground Pressure:	39.3/42.3 kPa
	Arm Length:	1820mm
	Safety Valves:	Yes, Included as Standard
	Bucket / Arm Digging Forces:	64/41 kN
	Minimum Swing Radius:	620/500 mm
	Maximum Dig Height / Depth:	6850/3993 mm
	Maximum Swing Speed:	12 rpm
	Maximum Swing Torque:	364 kN.m
	Maximum Traction:	64 kN
Maximum Dump Height:	4988 mm	
Operator Station	Canopy / Cabin Type:	Enclosed Cabin
	Canopy / Cabin Safety:	ROPS & FOPS
	Seat:	Air Suspension
Hydraulics	Display Screen:	Yes, Included as Standard
	Pump Make:	XCMG
	Hydraulic Pump Type:	Load Sensing Pump
	Maximum Flow:	219 LPM @ 2100 rpm
	Displacement:	104.3 cm ³ /rev
	Relief Pressure Valve:	326.4 kgf/cm ³
	Hydraulic Circuits:	AUX1 & AUX2
Additional Features	Track Shoe Width:	450 mm
	Emergency Stop:	Yes, Included as Standard
	Front Work Lights:	Yes, Included as Standard
	Reverse Camera:	Yes, Included as Standard
	Travel Alarm:	Yes, Included as Standard
Bucket/s Included:	Standard Capacity 0.35 m ³	

Note: specifications listed above are correct at March 2022 and are subject to change any time. For additional information visit www.xcmg.net.au.

ABOUT US

INDUSTRY EXPERTISE

XCMG is one of Australia's fastest growing construction, mining and agriculture equipment suppliers.

Offering premium quality excavators, wheel loaders, compaction rollers, graders, elevated work platforms and more, XCMG has the products and the support to keep you working on any job site.

MACHINERY SALES

XCMG know construction, mining and agri machinery. Count on our dedicated and knowledgeable team of product experts to take the time to understand and satisfy your machinery needs by recommending the right solution for the job.

AFTERMARKET SUPPORT

We're here to help keep you and your machine working. With an exceptional over-the-counter fill rate on spare parts, you're assured that when you buy an XCMG machine, you'll be looked after throughout your machine's entire lifetime, from start to finish.

Every service job is as important to us as it is to you, and with a dedicated team of machinery technicians, we have ample resources to look after any of your machine repairs or servicing requirements quickly and efficiently.

RENTALS & HIRE

If you need a high-performance machine with reliability you can trust, and the flexibility of hiring, we have you covered.

Our fleet is diverse, with machines to suit almost any job. Furthermore, because our rental fleet is maintained by factory-trained technicians, you can be confident that you'll not only be getting the best machines on the market, but that it's going to work as hard as you do, day-in day-out.

ABOUT

The World's 3rd largest manufacturer of construction and mining equipment.

Founded in 1943 - equipped with more than 8 decades of experience in the industry.

Manufacturing facilities located around the world: USA, Germany, China, Brazil and India.

Extensive supply chain and dealer network throughout Australia offering premium aftersales service and parts support.

Deep relationships with corporate giants Rio Tinto, BHP and MMG in Australia.

MINI / LARGE EXCAVATORS

1 to 100+ Tonne

WHEEL LOADERS

5 to 100 Tonne

COMPACTION ROLLERS

1.5 to 30 Tonne Smooth & Padfoot

GRADERS

7.5 to 70 Tonne

ACCESS EQUIPMENT

Lift Heights from 5 to 21 Metres

MINING TRUCKS

20 to 100 Tonne

FIND OUT MORE & LOCATE YOUR NEAREST DEALER:

www.xcmg.net.au

“XCMG: FOR YOUR SUCCESS”



YOUR LOCAL XCMG DEALER:



www.xcmg.net.au