

All Rights Reserved

Materials and specifications are subject to change without notice. Featured machines in photos may include additional equipment. See your XCMG dealer for available options.



XS-Series Single Drum Compactors

XS165



Roy Rossini - Deputy General Manager
Address: Level 10, 185 Victoria Square
Adelaide S.A 5000
Mobile: +61 0411 591 394 (Australia)
Email: royrossini@xcmg.com

XCMG ROAD MACHINERY BUSINESS DEPARTMENT
Address: No.1 Taoshan Road, Xuzhou Economic Developing Zone,
Jiangsu, China 221004
Tel: +86(0)516 8773 9703
Fax: +86(0)516 8773 9230
E-mail: zlservice@xcmg.com

www.xcmg.com





INTRODUCTION OF XCMG

XCMG, as a leading enterprise valued of 100 billion RMB, with the largest scale, the best technology level, the largest export volume, and high competitiveness and influence in China's construction machinery industry, has been occupying the first place in China's construction machinery industry for decades, and it now ranks the third in the world industry and the 395th among the world's top 500 brands. The main products by XCMG consists of 16 categories of equipment such as hoisting machinery, excavation machinery, concrete machinery, mining machinery, earth-moving machinery and road machinery, etc., as well as three categories of key components such as hydraulic system, transmission system and electric control system. Among above-mentioned, hoisting machinery ranks first in the world, and package solution of road construction and maintenance machinery, piling machinery and concrete machinery are among the first-class bloc in the world.

XCMG has accumulated more than 8000 approved patents, including more than 1900 invention patents and more than 130 PCT international patents. Entities of R&D centers, manufacturing plants or KD factories are in operation in more than 10 countries such as Germany, the United States, Brazil and India, XCMG has also acquired three European enterprises including Schwing in Germany. The Brazil manufacturing plant, with an investment of 350 million dollars to build up factories on a bare ground, has become a model of economic cooperation between China and Brazil. At present, XCMG products are exported to 187 countries and regions, covering 97% of the countries along "The Belt and Road" area. In export business to 35 countries, XCMG's proportion ranks NO. 1, with a steady first place within Chinese industry in terms of annual export volume and overseas income.

PRODUCT HIGHLIGHTS

The XS165 hydraulic drive, single drum vibratory roller features high vibratory force. Producing high compaction efficiency and compaction quality. It is used widely in compaction work on base layer, sub-base layer and rock fill for roads, railways, airports, harbors, dams and industrial construction sites.



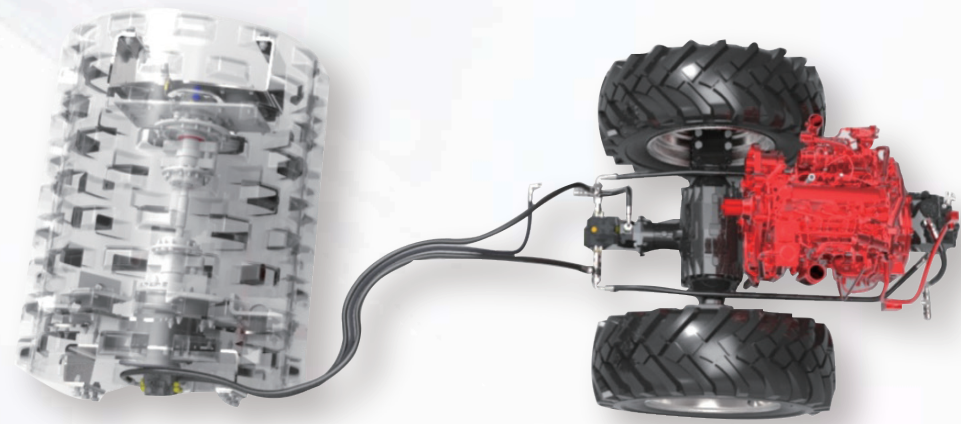

Drive Capability

Electric proportional anti-slip control enables up to 60% climbing ability,
Front and rear double hydraulic drive systems provide greater traction capability,
Drive axles with anti-slip differential for more efficient torque transmission.



PRODUCT HIGHLIGHTS



Compaction Performance

Dual frequency and dual amplitude

236/340kN vibration force achieves maximum compaction depth and is adaptable to different materials.



Drift-sand



Gravel-soil



Compaction quality

Three center coincidence

The drum "three center coincidence" technology and the amplitude uniformity control technology essentially guarantee the compaction quality and improve the efficiency of dynamic and static compaction.

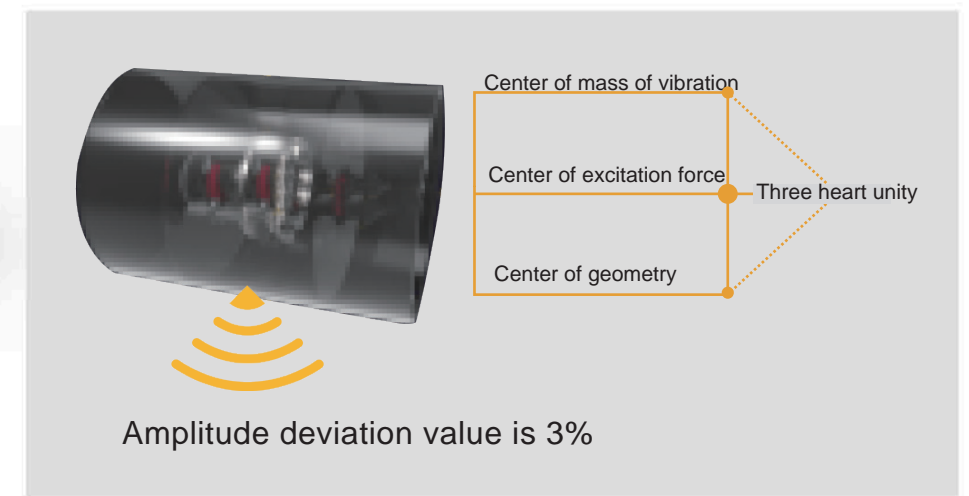
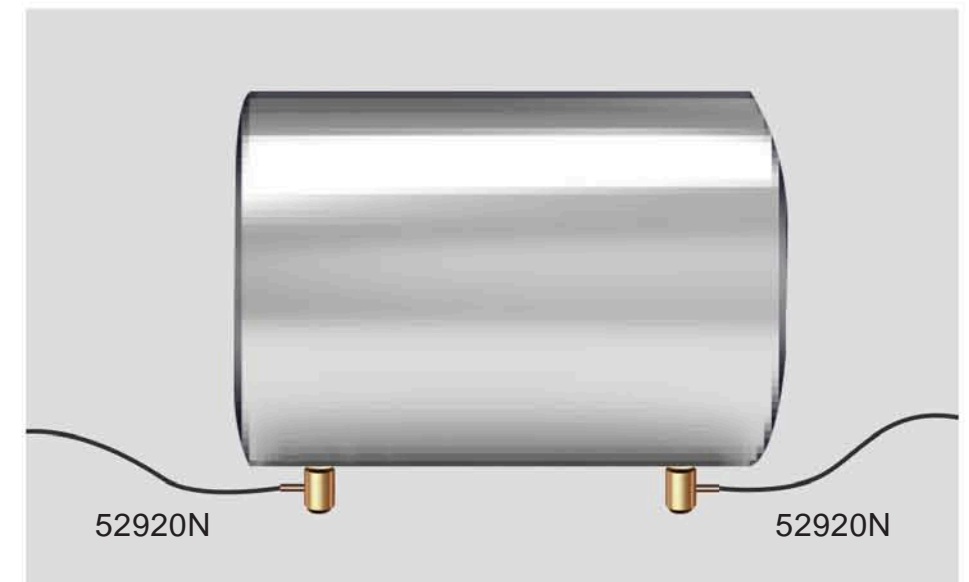

PRODUCT HIGHLIGHTS

Human Machine Interaction—security



Large curved glass, narrow waist design of rear frame, standard reversing camera and radar provide excellent driving visibility.

External power supply for jump starting machine.



Double rotary warning light and 360 vision camera and reversing alarm.

Front warm-air defrosting and rear heated wire windshield provide rapid defrosting and efficient defogging.

All-around insulated cabin to reduce the vibration of compaction on the driver.

External E-stop, providing easy emergency shutdown.

Full ROPS/FOPS cabin for operator safety.

Human Machine Interaction–illumination

Four LED working lights front and rear of cab provide excellent illumination for night operation.



Human Machine Interaction—comfort



- ① Cabin insulation provides a quiet operating environment.
 - ② Standard heating/cooling air conditioning, three-dimensional fan for balanced internal temperature, the fresh air system makes cleaner air in cabin.
 - ③ Wide suspension seat provides full support for operator and reduces whole body vibrations.
 - ④ Adjustable seat and steering column are engineered for
 - ⑤ optimised ergonomics for operator comfort.
- Electronic joystick integrates the drum vibration button for easy

Easy to Service

- Easy viewing LCD display and Audio- visual alarm on dashboard provides service and repair information.
- External oil filter and fuel filter for convenient servicing, large underhood maintenance.
- Engine hood is opened from ground level providing easy access.



DIMENSIONS

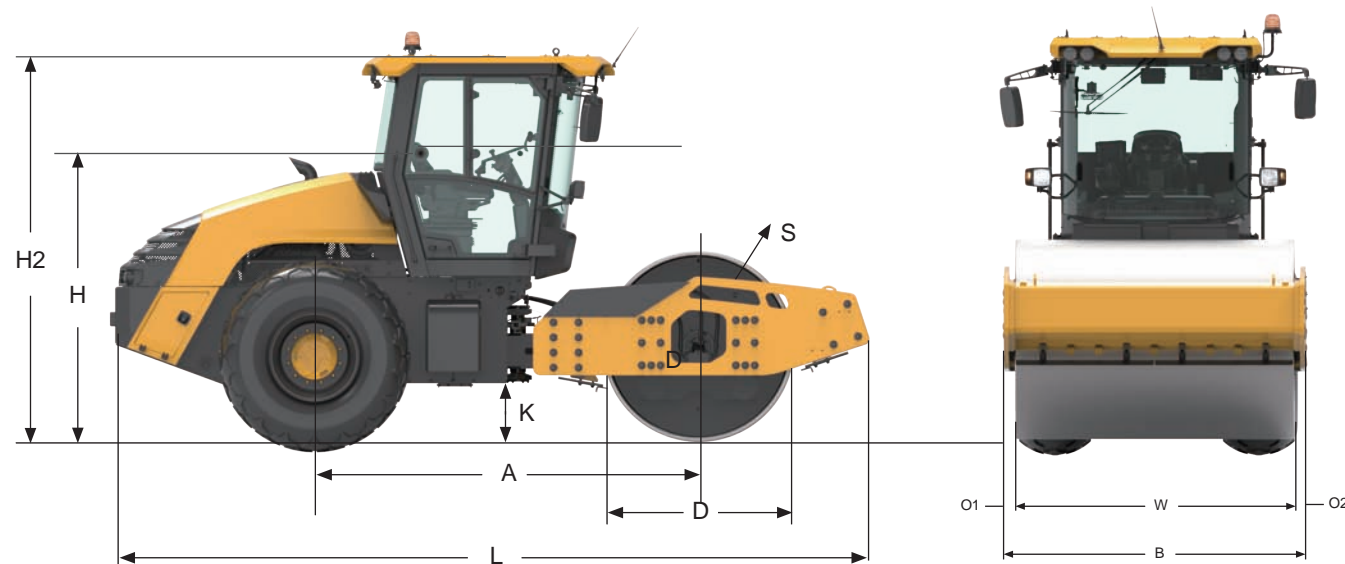

Dimensions (mm)	A	B	D	H	H2	K	L	O1	O2	S	W
XS165	3060	2300	1523	2390	3040	467	6010	83	85	30	2130

SPECIFICATIONS

Item	Content	Unit	XS165
Weights Parameters	Operating weight	kg	16000
	Maximum operating weight	kg	16000
	Front axle weight	kg	10800
	Rear axle weight	kg	5200
	Static linear load	N/cm	507
Maneuverability Parameters	Operating speed (First/Second gear)	km/h	0~11.0
	Theoretical gradeability	%	60
	Minimum extern turning radius	mm	3766
	Minimum ground clearance	mm	417
	Wheel base	mm	3060
	Steering angle	°	±35
	Oscillation angle	°	±10
Compaction Performance	Vibration frequency (LF/HF)	Hz	28/33
	Nominal amplitude (High/Low amplitude)	mm	2.0/1.0
	Exciting force (LF/HF)	kN	340/236
	Drum diameter	mm	1523
	Compaction width	mm	2130
Engine	Model	-	QSB4.5
	Rated power	kW	119
	Rated speed	r/min	2200
Tire	Spec.	-	23.1-26-12G23TL
	Ply rating	-	12
	Air pressure	kPa	200
Service refill capacities	Fuel tank	L	260
	Urea tank	L	12

Optimum services , XCMG Guaranteed



Professional Integrated Complete Solutions

XCMG group has built a strong reputation based on the quality, reliability and durability of its construction machinery. What's more, XCMG has gradually established a service network to constantly provide its local integrated and highly efficient complete solutions for all users.

Full range of services ready for you

In order to respond to your needs as fast as possible, XCMG experts are on their way to your job site from one of our facilities near you. Full range of services are available in order to reduce your total cost of ownership and increase your revenue.



XCMG Global Spareparts System

